

DIMENSIONS

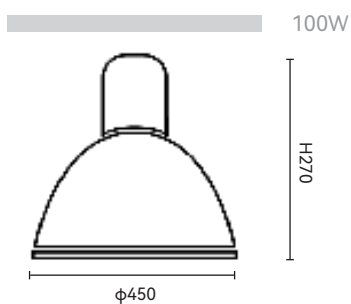

Unit:mm

PRODUCT

NO.	ZLHB-1001-100W
LED	Cree / Bridgelux / Osram / Epistar
Watts	100W
Lumens	100lm/w
CRI	>80
Color Temperature	3000K / 4000K / 6000K
light body size	φ450*H270mm
Driver	Olala
AC Input	220-240V / 50/60Hz
Color	Black
Installation	Chain hoist installation
Storage Temperature Range	Temperature:-20°C to +50°C Humidity: 85%
Standards of Safety	EN 60598-1:2008+A11:2009 EN 60598-2-2:2012

Features:

- High-brightness led chip and high-efficiency, anti-glare and economical multi-size design, corresponding to the needs of different place.
- Secondary optical design, high light transmittance, unique PC light transmittance makes the light smooth and full.
- Secondary optical design, high light transmittance, unique PC light transmittance makes the light smooth and full.
- The spectrum does not contain red or ultraviolet light, which protects the eyes.

Application:

Widely used in workshops, mines, factories, shipyards, warehouses, highway toll stations, gas stations, large supermarkets, exhibition halls, gymnasiums and other places that require industrial and mining lighting.

